

3D SERIES

NORMALISED AND MONOBLOCK CENTRIFUGAL ELECTROPUMPS CONFORMING TO EN 733 (EX DIN 24255)

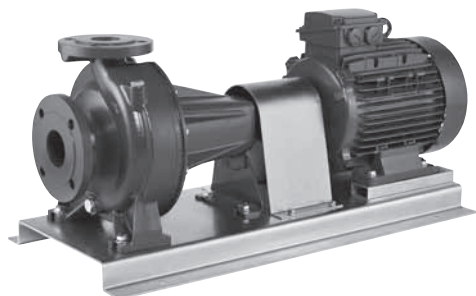

Cast iron monoblock (3D) and normalised centrifugal electropumps conforming to EN 733 (3DS-3DP).

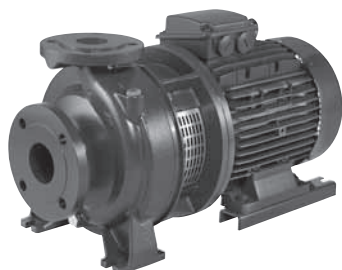
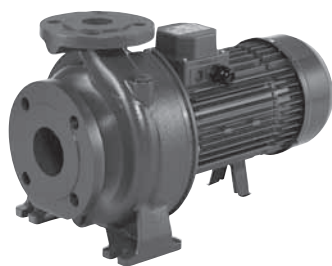

APPLICATIONS

- Handling of water and clean, chemically non-aggressive liquids
- Water supply
- Pressurisation
- Washing and industrial plants
- Water circulation in climate control systems
- Irrigation and agriculture

TECHNICAL FEATURES

- Highly robust construction
- Stainless steel impeller
- High efficiency

PUMP SPECIFICATIONS

- Maximum operating pressure: 10 bar
- Temperature of the liquid:
 - 5°C – +90°C
 - 5°C – +110°C (versions H-HS-HW-HSW)
 - 5°C – +120°C (version E)
- MEI > 0.4

For further information, please consult our Data Books on the website www.ebaraurope.com

MOTOR SPECIFICATIONS

- IE2 high energy-efficiency motors starting from 0.75kW
- IE3 high energy-efficiency motors starting from 7.5kW up to 22kW
- Self-ventilated 2-pole and 4-pole motors
- Isolation class F (B for high temperatures)
- Protection rating IP 55
- Single-phase voltage 230V ±10%, 50Hz, three-phase voltage 230/400 ±10% (up to 4kW included) 50Hz, three-phase voltage 400/690V ±10% (from 5.5 kW and above) 50Hz
- Protection to be arranged by the user

MATERIALS

- Cast iron pump body EN-GJL-250-EN 1561
- Impeller made of:
 - AISI 304 steel for SERIES 3D 32, 40, 50
 - AISI 316 microcast steel for SERIES 3D 65
- AISI 304 steel shaft (part coming into contact with liquid)
- Mechanical seal made of:
 - Ceramic/Carbon/NBR (standard)
 - Ceramic/Carbon/FPM (version H)
 - SiC/SiC/FPM (version HS)
 - Tungsten carbide/Tungsten carbide/FPM (version HW)
 - SiC/Tungsten carbide/FPM (version HSW)
 - Ceramic/Carbon/EPDM (version E)

SPECIAL VERSIONS

- Special voltages
- Special mechanical seals

Available in 3 different versions with 2-pole and 4-pole motors

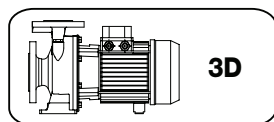

3D

Monoblock with extended motor shaft

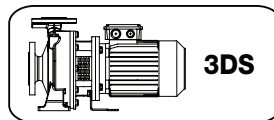

3DS

Monoblock with standard motor and rigid joint

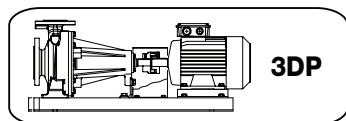

3DP

On base, with standard motor and elastic joint

3DPF version (only hydraulic part) available on request



3D SERIES

NORMALISED AND MONOBLOCK CENTRIFUGAL ELECTROPUMPS CONFORMING TO EN 733 (EX DIN 24255)

IDENTIFICATION CODE

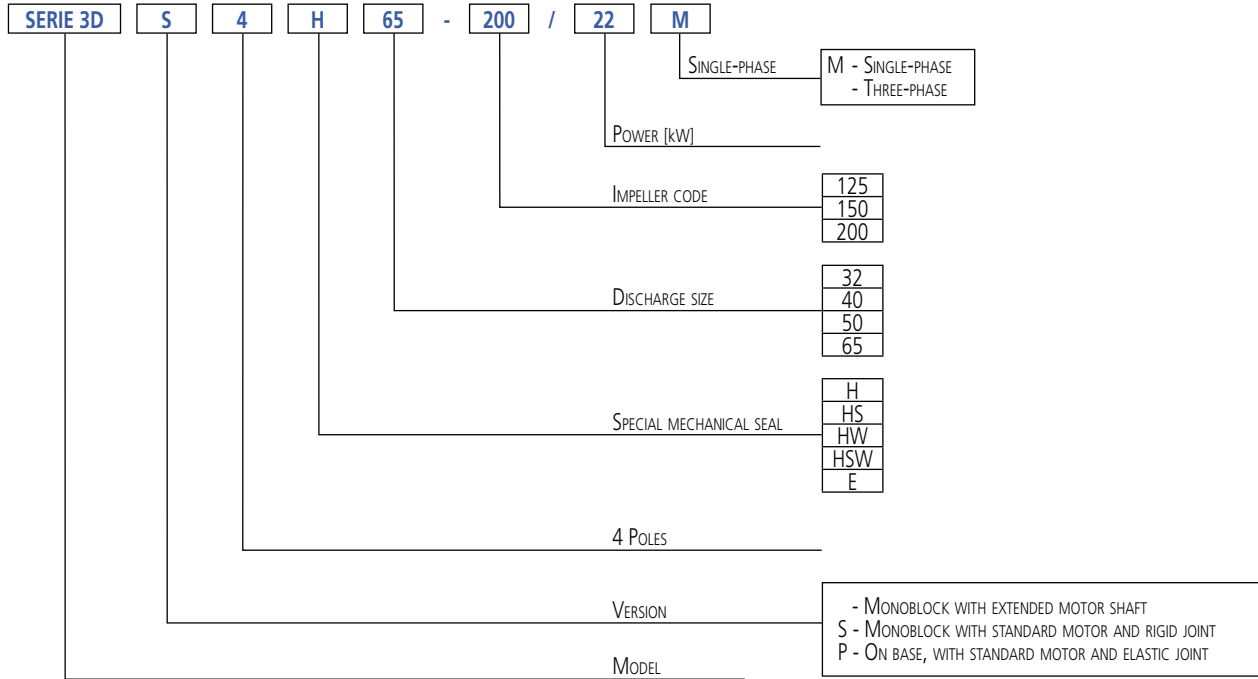

The contents of this publication must not be regarded as binding. EBARA Pumps Europe S.p.A. reserves the right to effect any modification it deems necessary, without prior notice.



3D SERIES

NORMALISED AND MONOBLOCK CENTRIFUGAL ELECTROPUMPS CONFORMING TO EN 733 (EX DIN 24255)

PERFORMANCE RANGE at 2900 min⁻¹ (according to ISO 9906 Attachment A)

2 Poles

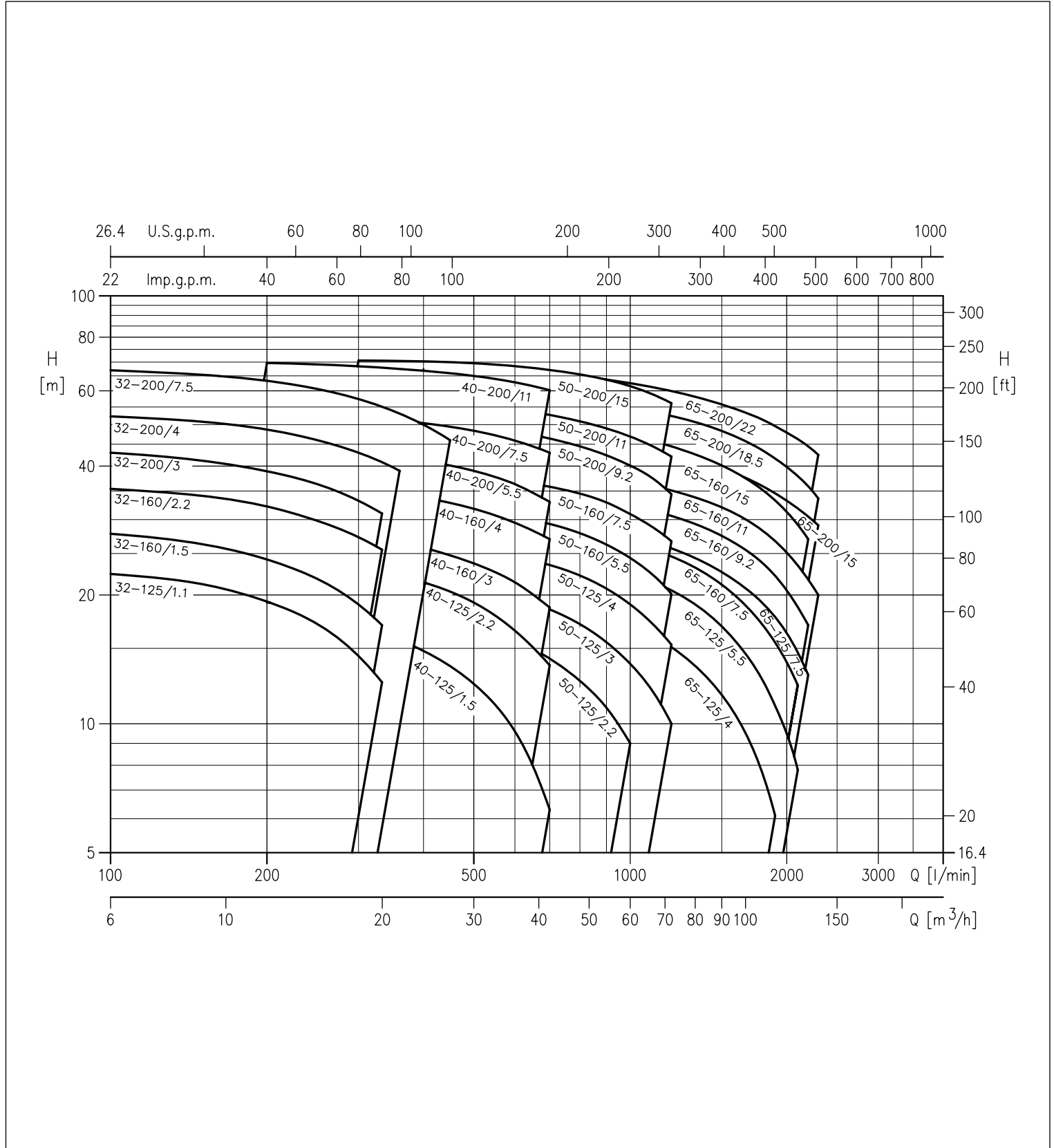

The contents of this publication must not be regarded as binding. EBARA Pumps Europe S.p.A. reserves the right to effect any modification it deems necessary, without prior notice.

3D SERIES

NORMALISED AND MONOBLOCK CENTRIFUGAL ELECTROPUMPS CONFORMING TO EN 733 (EX DIN 24255)

SERIES 3D(.) 32 PERFORMANCE TABLE

2 Poles

Model	P ₂		Q=Flow rate									
	[HP]	[kW]	l/min	100	150	200	250	300	333	360	400	450
			m ³ /h	6	9	12	15	18	20	21,6	24	27
			H=Head [m]									
3D(.) 32-125/1.1 (M)	1,5	1,1	22,4	21,2	19,3	17,1	14,4	12,5	-	-	-	-
3D(.) 32-160/1.5 (M)	2	1,5	27,5	25,9	23,7	21,3	18,5	16,4	-	-	-	-
3D(.) 32-160/2.2 (M)	3	2,2	35,4	34,1	32,2	29,8	27,3	25,5	-	-	-	-
3D(.) 32-200/3.0	4	3	43,0	41,0	39,0	36,5	33,0	31,0	-	-	-	-
3D(.) 32-200/4.0	5,5	4	52,5	51,0	49,0	46,0	43,0	41,0	39,0	-	-	-
3D(.) 32-200/7.5	10	7,5	67,0	65,0	63,0	61,0	57,0	55,0	53,0	50,0	46,0	-

SERIES 3D(.) 40 PERFORMANCE TABLE

2 Poles

Model	P ₂		Q=Flow rate									
	[HP]	[kW]	l/min	200	250	300	350	400	450	500	600	700
			m ³ /h	12	15	18	21	24	27	30	36	42
			H=Head [m]									
3D(.) 40-125/1.5 (M)	2	1,5	18,2	17,6	16,8	15,9	14,8	13,7	12,4	9,6	6,3	-
3D(.) 40-125/2.2 (M)	3	2,2	24,4	23,9	23,2	22,4	21,4	20,4	19,2	16,5	13,7	-
3D(.) 40-160/3.0	4	3	29,4	28,7	27,8	26,8	25,8	24,8	23,7	21,4	18,7	-
3D(.) 40-160/4.0	5,5	4	37,2	36,5	35,7	34,8	33,8	32,8	31,8	29,5	27,0	-
3D(.) 40-200/5.5	7,5	5,5	44,5	44,0	43,0	42,0	41,0	40,0	39,0	36,3	33,0	-
3D(.) 40-200/7.5	10	7,5	53,5	53,0	52,0	51,5	50,5	49,5	48,5	46,0	43,0	-
3D(.) 40-200/11	15	11	70,0	69,0	68,5	67,5	67,0	66,0	65,0	63,0	60,0	-

SERIES 3D(.) 50 PERFORMANCE TABLE

2 Poles

Model	P ₂		Q=Flow rate									
	[HP]	[kW]	l/min	400	500	600	700	800	900	1000	1100	1200
			m ³ /h	24	30	36	42	48	54	60	66	72
			H=Head [m]									
3D(.) 50-125/2.2 (M)	3	2,2	18,0	17,0	15,7	14,2	12,6	10,9	9,0	-	-	-
3D(.) 50-125/3.0	4	3	21,5	20,8	19,8	18,5	17,1	15,5	13,8	12,0	10,0	-
3D(.) 50-125/4.0	5,5	4	25,8	25,3	24,5	23,5	22,2	20,7	19,0	17,2	15,3	-
3D(.) 50-160/5.5	7,5	5,5	32,0	31,5	30,5	29,3	27,9	26,2	24,4	22,4	20,0	-
3D(.) 50-160/7.5	10	7,5	38,2	37,6	36,9	35,8	34,5	32,9	30,9	28,9	26,7	-
3D(.) 50-200/9.2	12,5	9,2	-	49,5	48,0	46,5	44,5	42,5	40,0	37,6	34,4	-
3D(.) 50-200/11	15	11	-	55,5	54,5	52,5	51,0	49,0	47,0	44,5	42,0	-
3D(.) 50-200/15	20	15	-	69,5	68,5	67,0	65,5	63,5	61,5	59,0	56,0	-

SERIES 3D(.) 65 PERFORMANCE TABLE

2 Poles

Model	P ₂		Q=Flow rate									
	[HP]	[kW]	l/min	600	700	1000	1300	1600	1900	2100	2200	2300
			m ³ /h	36	42	60	78	96	114	126	132	138
			H=Head [m]									
3D(.) 65-125/4.0	5,5	4	20,4	19,8	17,2	14,0	10,4	6,0	-	-	-	-
3D(.) 65-125/5.5	7,5	5,5	-	25,0	22,5	19,4	15,5	11,0	8,0	-	-	-
3D(.) 65-125/7.5	10	7,5	-	29,6	27,5	24,7	21,5	17,8	14,7	13,0	-	-
3D(.) 65-160/7.5	10	7,5	-	29,0	26,6	23,5	19,8	15,5	12,3	-	-	-
3D(.) 65-160/9.2	12,5	9,2	-	34,7	32,4	29,6	26,3	22,2	18,8	17,0	-	-
3D(.) 65-160/11	15	11	-	39,0	37,0	34,0	31,0	27,0	23,0	22,0	20,0	-
3D(.) 65-160/15	20	15	-	46,0	44,0	41,5	38,4	34,6	31,9	30,5	29,0	-
3D(.) 65-200/15	20	15	-	51,0	47,0	43,0	38,6	33,3	29,2	27,0	-	-
3D(.) 65-200/18.5	25	18,5	-	58,0	55,0	51,0	47,0	41,5	37,9	35,9	33,6	-
3D(.) 65-200/22	30	22	-	65,5	62,5	58,5	54,5	49,5	46,0	44,5	42,5	-

(M) Single-phase version only for 3D SERIES

3D SERIES

**NORMALISED AND MONOBLOCK CENTRIFUGAL ELECTROPUMPS
CONFORMING TO EN 733 (EX DIN 24255)**

DIMENSIONS 3D SERIES - up to 11kW

2 Poles

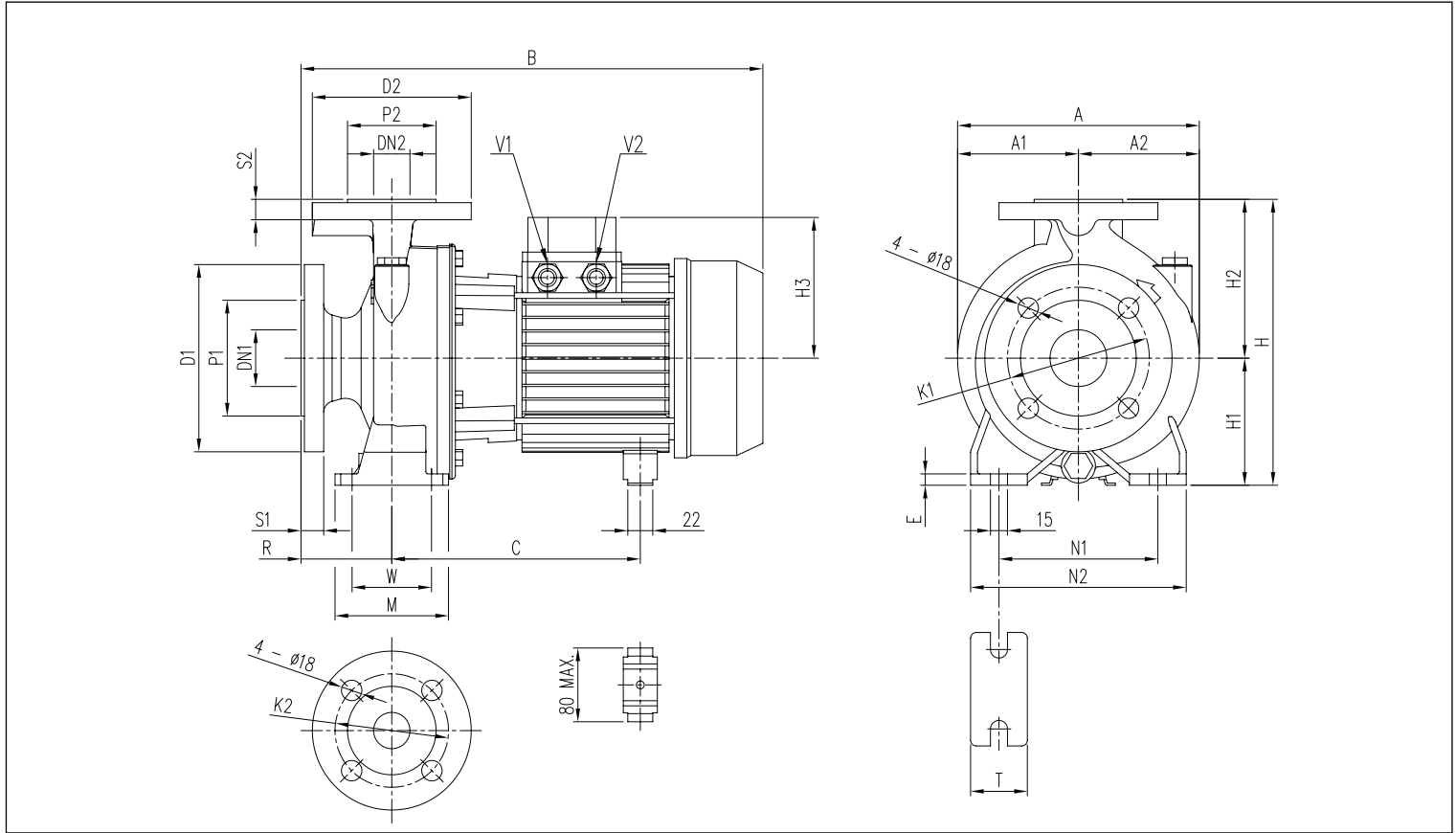

DIMENSIONAL TABLE

Model	Dimensions [mm]																												Weight [kg]									
	DN1 Ø	P1 Ø	K1 Ø	D1 Ø	S1	DN2 Ø	P2 Ø	K2 Ø	D2 Ø	S2	H	H1	H2	H3 [2]	[1]	R	W	M	N1	N2	T	E	A	A1	A2	B [2]	[1]	[*]	C [2]	[1]	V1 [1]	[2]	V2 [1]	[2]	[1]	[*]		
3D 32-125/1.1(M)	50	102	125	165	20	32	78	100	140	18	252	112	140	141	124	80	70	100	140	190	50	10	213	106.5	106.5	408	407	-	219±230	219±230	-	M20x1,5	PG13,5	25,0	29,5	-		
3D 32-160/1.5(M)	50	102	125	165	20	32	78	100	140	18	292	132	160	141	124	80	70	100	190	240	50	10	254	127	127	408	432	-	219±230	219±230	-	M20x1,5	PG13,5	29,0	33,5	-		
3D 32-160/2.2(M)	50	102	125	165	20	32	78	100	140	18	292	132	160	141	124	80	70	100	190	240	50	10	254	127	127	408	432	-	219±230	244±255	-	M20x1,5	PG13,5	35,7	36,0	-		
3D 32-200/3.0	50	102	125	165	20	32	78	100	140	18	340	160	180	-	124	80	70	100	190	240	50	10	296	148	148	-	471	-	-	244±255	-	-	PG13,5	-	PG16	-	47,5	-
3D 32-200/4.0	50	102	125	165	20	32	78	100	140	18	340	160	180	-	141	80	70	100	190	240	50	10	296	148	148	-	494	-	-	253	-	-	PG16	-	PG16	-	50,0	-
3D 32-200/7.5	50	102	125	165	20	32	78	100	140	18	340	160	180	-	150	80	70	100	190	240	50	10	296	148	148	-	519	539	-	275	PG13,5	-	PG16	-	PG16	-	62,0	65,1
3D 40-125/1.5(M)	65	122	145	185	20	40	88	110	150	18	252	112	140	141	124	80	70	100	160	210	50	10	220	108	112	408	407	-	219±230	219±230	-	M20x1,5	PG13,5	25,5	30,0	-		
3D 40-125/2.2(M)	65	122	145	185	20	40	88	110	150	18	292	132	160	-	124	80	70	100	190	240	50	12	254	127	127	-	471	-	-	244±255	-	-	PG13,5	-	PG16	-	39,0	-
3D 40-160/3.0	65	122	145	185	20	40	88	110	150	18	292	132	160	-	141	80	70	100	190	240	50	12	254	127	127	-	494	-	-	253	-	-	PG16	-	PG16	-	48,0	-
3D 40-160/4.0	65	122	145	185	20	40	88	110	150	18	292	132	160	-	141	80	70	100	190	240	50	12	254	127	127	-	494	-	-	253	-	-	PG16	-	PG16	-	60,0	-
3D 40-200/5.5	65	122	145	185	20	40	88	110	150	18	340	160	180	-	150	100	70	100	212	265	50	12	296	148	148	-	539	-	-	275	PG13,5	-	PG16	-	PG16	-	63,0	66,1
3D 40-200/7.5	65	122	145	185	20	40	88	110	150	18	340	160	180	-	150	100	70	100	212	265	50	12	296	148	148	-	539	559	-	275	PG13,5	-	PG16	-	PG16	-	63,0	66,1
3D 40-200/11	65	122	145	185	20	40	88	110	150	18	340	160	180	-	178	100	70	100	212	265	50	12	296	148	148	-	595	-	-	359	PG13,5	-	PG21	-	PG21	-	80,0	82,4
3D 50-125/2.2(M)	65	122	145	185	20	50	102	125	165	20	292	132	160	141	124	100	70	100	190	240	50	10	254	127	127	428	452	-	219±230	244±255	-	M20x1,5	PG13,5	34,4	37,0	-		
3D 50-125/3.0	65	122	145	185	20	50	102	125	165	20	292	132	160	-	124	100	70	100	190	240	50	10	254	127	127	-	491	-	-	244±255	-	-	PG13,5	-	PG16	-	39,5	-
3D 50-125/4.0	65	122	145	185	20	50	102	125	165	20	292	132	160	-	141	100	70	100	190	240	50	10	254	127	127	-	514	-	-	253	-	-	PG16	-	PG16	-	48,0	-
3D 50-160/5.5	65	122	145	185	20	50	102	125	165	20	340	160	180	-	150	100	70	100	212	265	50	10	296	148	148	-	539	-	-	275	PG13,5	-	PG16	-	PG16	-	60,0	-
3D 50-160/7.5	65	122	145	185	20	50	102	125	165	20	340	160	180	-	150	100	70	100	212	265	50	10	296	148	148	-	539	559	-	275	PG13,5	-	PG16	-	PG16	-	64,0	67,1
3D 50-200/9.2	65	122	145	185	20	50	102	125	165	20	360	160	200	-	178	100	70	100	212	265	50	10	296	148	148	-	595	-	-	359	PG13,5	-	PG21	-	PG21	-	69,5	72,6
3D 50-200/11	65	122	145	185	20	50	102	125	165	20	360	160	200	-	178	100	70	100	212	265	50	10	296	148	148	-	595	-	-	359	PG13,5	-	PG21	-	PG21	-	80,0	82,4
3D 65-125/4.0	80	138	160	200	22	65	122	145	185	20	340	160	180	-	141	100	95	125	212	280	65	12	263	127	136	-	514	-	-	253	-	-	PG16	-	PG16	-	53,0	-
3D 65-125/5.5	80	138	160	200	22	65	122	145	185	20	340	160	180	-	150	100	95	125	212	280	65	12	263	127	136	-	539	-	-	275	PG13,5	-	PG16	-	PG16	-	65,0	-
3D 65-125/7.5	80	138	160	200	22	65	122	145	185	20	340	160	180	-	150	100	95	125	212	280	65	12	263	127	136	-	539	559	-	275	PG13,5	-	PG16	-	PG16	-	69,5	72,6
3D 65-160/7.5	80	138	160	200	22	65	122	145	185	20	360	160	200	-	150	100	95	125	212	280	65	12	296	148	148	-	539	559	-	275	PG13,5	-	PG16	-	PG16	-	70,0	73,1
3D 65-160/9.2	80	138	160	200	22	65	122	145	185	20	360	160	200	-	178	100	95	125	212	280	65	12	296	148	148	-	595	-	-	359	PG13,5	-	PG21	-	PG21	-	85,0	85,0
3D 65-160/11	80	138	160	200	22	65	122	145	185	20	360	160	200	-	178	100	95	125	212	280	65	12	296	148	148	-	595	-	-	359	PG13,5	-	PG21	-	PG21	-	85,0	87,4

[1]= Only three-phase [2]= Only single-phase [*]= Only IE3 motors

The contents of this publication must not be regarded as binding. EBARA Pumps Europe S.p.A. reserves the right to effect any modification it deems necessary, without prior notice.

3D SERIES

**NORMALISED AND MONOBLOCK CENTRIFUGAL ELECTROPUMPS
CONFORMING TO EN 733 (EX DIN 24255)**

DIMENSIONS 3D SERIES - from 15kW and above

2 Poles

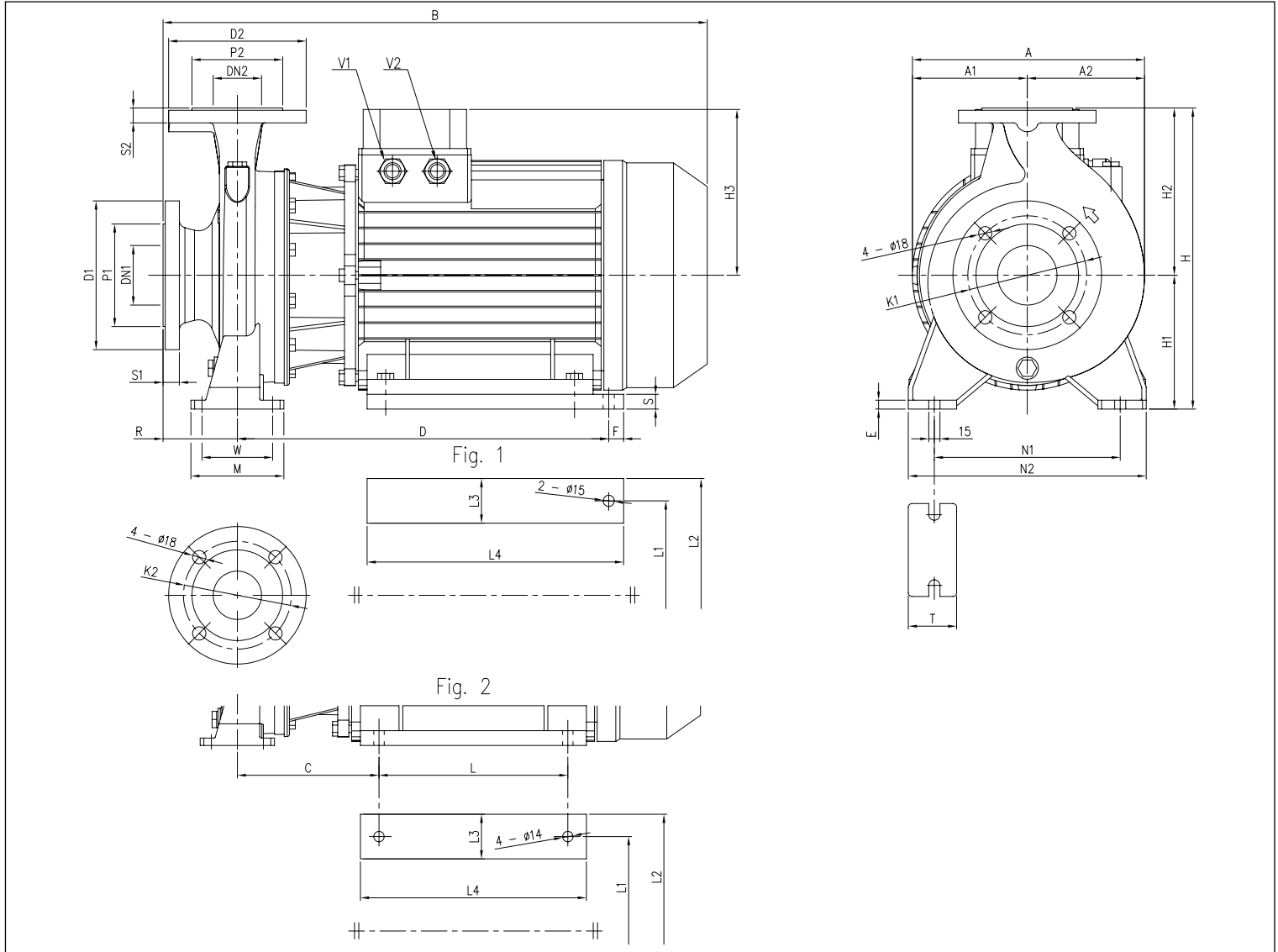

DIMENSIONAL TABLE

Model	Dimensions [mm]																				Weight [kg]																		
	DN1	P1	K1	D1	S1	DN2	P2	K2	D2	S2	H	H1	H2	H3	Fig.	R	W	M	N1	N2	T	E	A	A1	A2	B	C	L	L1	L2	L3	L4	D	F	S	V1	V2	[*]	[*]
3D 50-200/15	65	122	145	185	20	50	102	125	165	20	360	160	200	223	2	100	70	100	212	265	50	10	296	154,5	141,5	723	190,5	254	254	318	64	304	-	-	-	PG 21	PG 21	121,0	124,1
3D 65-160/15	80	138	160	200	22	65	122	145	185	20	360	160	200	223	2	100	95	125	212	280	65	12	296	154,5	141,5	732	199,5	254	254	318	64	304	-	-	-	PG 21	PG 21	126,0	129,1
3D 65-200/15	80	138	160	200	22	65	122	145	185	20	405	180	225	223	1	100	95	125	250	320	65	12	312	154,5	157,5	732	-	-	254	314	60	345	499,5	20	20	PG 21	PG 21	126,0	129,1
3D 65-200/18.5	80	138	160	200	22	65	122	145	185	20	405	180	225	223	1	100	95	125	250	320	65	12	312	154,5	157,5	732	-	-	254	314	60	345	499,5	20	20	PG 21	PG 21	140,0	146,3
3D 65-200/22	80	138	160	200	22	65	122	145	185	20	405	180	225	223	1	100	95	125	250	320	65	12	312	154,5	157,5	732	-	-	254	314	60	345	499,5	20	20	PG 21	PG 21	152,0	158,1

[*]= Only for IE3 motors

The contents of this publication must not be regarded as binding. EBARA Pumps Europe S.p.A. reserves the right to effect any modification it deems necessary, without prior notice.